

Filtration & Technology in Coal Preparation Plants



**B
O
K
E
L
A**



Leadership in Filtration Technology - Centre of Excellence for Solid/Liquid Separation in coal beneficiation

BOKELA is *the* HighTech company in the field of separation processes and innovations. Our unique know-how and comprehensive services are asked for by clients world-wide and give us an outstanding position.

Our engineers are in a **permanent dialogue** with the experts from coal washeries and perform high efficient solutions for filtration and centrifugation tasks.

BOKELA rotary vacuum filters and the modern **Hi-Bar Filtration** technology for continuous pressure and steam pressure filtration are pace-making technologies which define the state of the art.

Furthermore, with our **revamping concept** for the modernization of running filter plants we have achieved market leadership. By upgrading and modernization of used running filters we make it possible to improve the filtration process significantly or even to re-vitalise shut down filters for new applications. The Bokela disc filter upgrades have won for the BMA business a “**Business Excellence Six Sigma Award**” from **BHP-Billiton** for replication of leading practice in the alumina industry into the coal industry. Site visits to Worsley Alumina by BMA teams showed what was possible with the latest technology disc filters of BOKELA.

BOKELA provides unique engineering services around any filtration step used by our clients to design most modern separation processes and to open access to remarkable cost savings. World-wide, BOKELA is well-known and highly regarded by its clients for:

- tailor-made solutions
- long-termed partnership
- integral project engineering
- unique revamping of running filters
- pace-making in modern filtration technologies.

BOKELA Rotary Filters for Coal Washeries

BOKELA rotary filters define a new state of the art in rotary filter technology and surprise with numerous innovations. For fine coal filtration tasks the BOKELA rotary filter family comprises

- vacuum disc filters
- vacuum drum filters
- Hi-Bar disc and drum filters for continuous pressure or steam pressure filtration.

The innovative design of our high performance rotary filters is the result of pioneering research and reflects the know how and experience from numerous filter optimisation projects. Based on the experience gained in more than 250 filter optimisation / revamping projects for all major filter types and OEMs, BOKELA has developed a new generation of disc and drum filters incorporating a number of innovative changes to conventional design practice.

Most of these innovations have been made to resolve capacity and performance problems related to hardware bottlenecks and poor hardware design. Faced with the weak points of these conventional technologies we designed the new generation of rotary filters leading to significantly improved process results in coal filtration and in various other industries all over the world.

The superior process design and mechanical design and the excellent hydraulic characteristics result in

- extraordinary high throughput capacity
- large filter area per footprint, i.e. low footprint area
- very high capacity per filter unit
- safe operation, high availability and high flexibility
- advanced process control system
- low operation and maintenance cost.

BOKELA Disc Filter – the Boozer

With the Boozer disc filter BOKELA has created a new generation of disc filters that set a new standard for fine coal filtration. The innovative process design and mechanical design of the Boozer provide for excellent hydraulic characteristics, outstanding performance capacity, safe operation and excellent maintainability.

New Standard for Fine Coal Filtration

Filtration of coal slurries with the Boozer is characterised by

- 100 % higher pressure difference at the filter cloth compared to conventional disc filters due to optimal hydraulic design leading to minimal pressure drop
- high specific throughput capacity
 - double capacity compared to conventional disc filters
 - 30 % higher capacity compared to belt filters
- low moisture content even at high throughput capacity
- large filter area per footprint of $7.5 \text{ m}^2/\text{m}^2$, i.e. extremely low footprint
 - only 25 % – 30 % floor space compared to belt filters
- high filter speed of up to 4 rpm
(for other products: up to 6 rpm, conventional disc filters: max. 3 rpm)
- complete cake discharge even at high filter speed
- high operational reliability and flexibility
i.e. capability to handle fairly large variations in feed flow rate and particle size distribution
- fully automatic operation, start and stop
 - level control operation by adaptation of filter speed, i.e. operation without steady overflow
- easy maintenance



Boozer ME-Type for coal filtration with exchangeable filtrate pipes, 8 discs and 140 m^2 filter area in the workshop

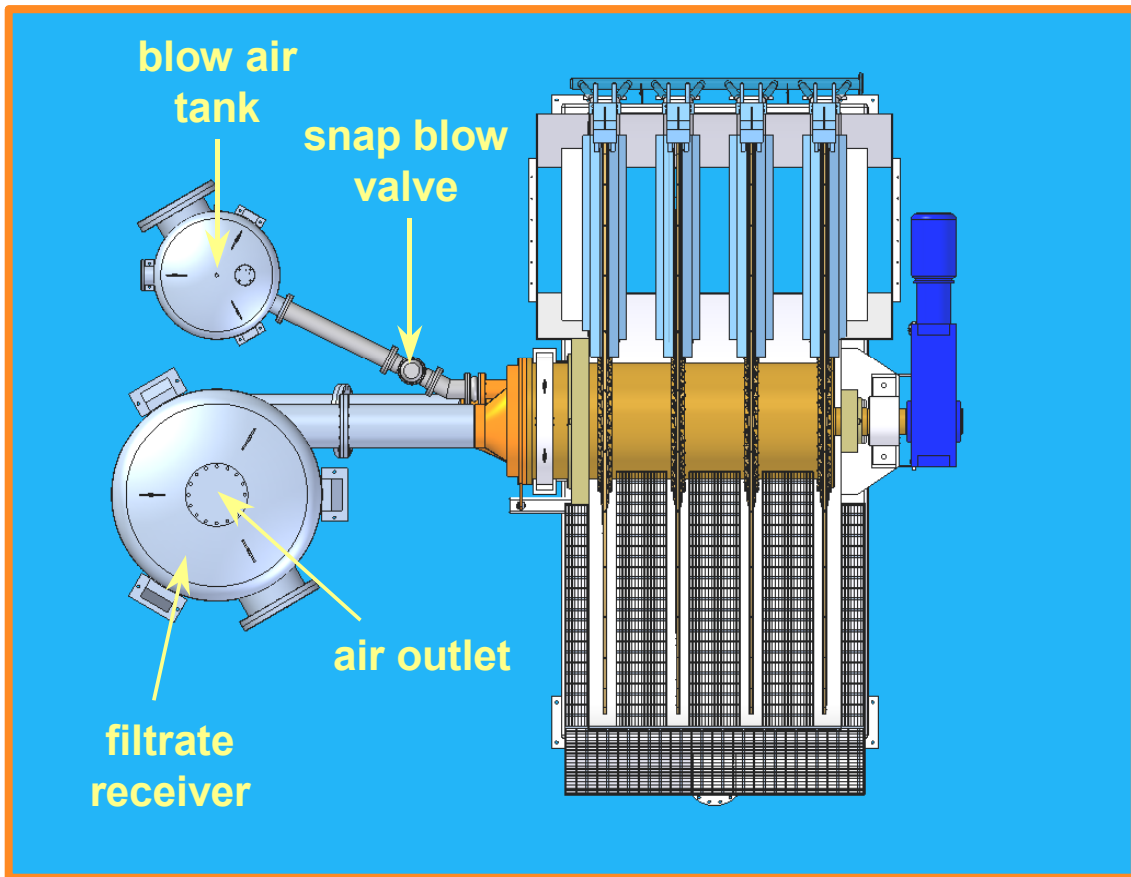

Installation of a Boozer disc filter
 pipes from control head to receivers without bends, tangential receiver inlet: i.e. minimal flow restrictions

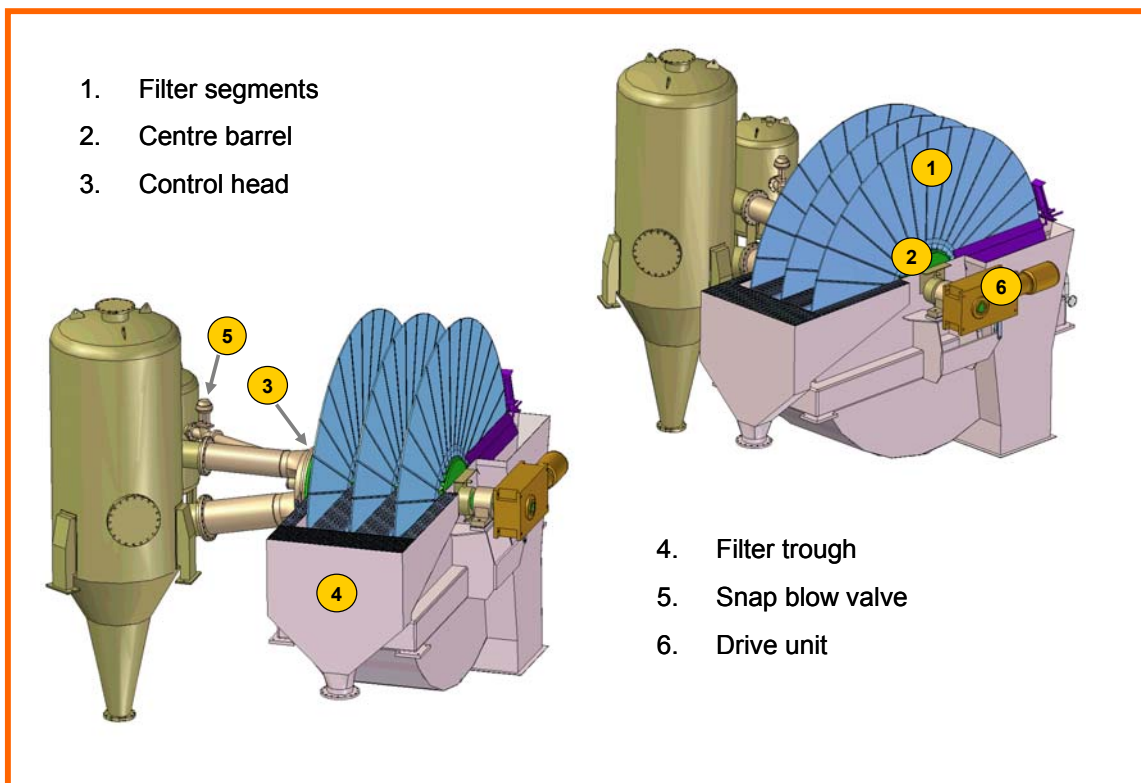

Main components of the Boozer disc filter

Superior Filter Design with Excellent Hydraulic Characteristics

The excellent performance and operation behaviour of the Boozer are the result of a complete new filter design in which all filter parts have been addressed like segments, filtrate pipes, centre barrel and bearings, filter trough, control head and cake discharge.

The most important innovations and improvements are



Cloth fastening with cable ties



Permanent walkways allow easy access



Complete discharge of coal filter cake

- large number of up to 30 segments per disc leading to small sized segments
- new segment design i.e.
 - zero resistance design provides for massive hydraulic capacity to process large filtrate flow rates and enables filtrate drainage and cake discharge in 0.2 seconds
 - light weight segments of less than 20 kg with quick release bayonet connections for ease of installation and removal - no tie rods!
 - quick fit filter bag system to allow cable ties to seal the neck and to provide high filtrate clarity by smooth and tight fit of filter bags
- filter designed to use poly bags which are easier to replace and more cost effective than metallic bags
- high performance control head with
 - pre-separation of air and liquid providing for low pressure loss at high capacities
 - back suck on the filter cloth to prevent damage on the scrapers during cake discharge.
- removable filtrate pipes (for abrasive products)
- permanent walkways to allow easy access to replace segments with holed cloths
- new filter trough design
 - eliminates agitators by being self agitating
 - enables control of slurry level
 - 50 % submergence of the disc into the slurry
- centre barrel and bearings designed for the high loads encountered with high capacity
- gearbox and motor designed for
 - high loads at low speeds
 - high speeds to enable full operating range for fully automatic control

Boozer ME-Type Replaces Three Filters of Old Design

In May 2006 a Boozer ME-Type started operation at DSK (Deutsche Stein Kohle) Bergwerk West CHPP in Germany). The new filter replaces three drum filters of 1960's design and fits into the narrow filter building without rebuilding measures. The filtration area is 140 m² and the Filter was specially designed for this application with 8 discs of 3.6 m in diameter which is a smaller size than the regular M-Type filter.



Trough of Boozer ME-Type (8 discs, 140 m² filter area) in the workshop



View of the running filter. The Boozer replaces 3 old drum filters and has a solids capacity of 320 kg/m²h ($x_{50} < 60 \mu\text{m}$, $C_{\text{solids,feed}} = 278 \text{ g/l}$)

Two Boozer L4-Type Disc Filters Saved over \$2 Million in Capital

Blackwater Mine, QLD, decided in favour of two Boozer L4-Type disc filters and saved over \$2 million in capital compared to belt filters due to the high capacity, simple design and small footprint of the Boozer disc filters. Compared to belt filters the Boozers need only some 75 % of the filtration area for the same solids capacity, require some 50 % of capital per m² filter area and need less than 40 % floor space.



Filter without segments lifted into position in the filter building



The two Boozer L4-Type disc filters in the filter building (without segments) – view from above to common access platform

Boozer Disc Filter Sizes (ME-Type)

| Filter Type | [-] | XS | S | ME | L |
|------------------------------------|-------------------|------------------|-------------------|--------------------|--------------|
| Disc Diameter | [m] | 2.2 | 3,2 | 4.1 | 5.6 |
| Filtration Area | [m ²] | 12 – 36 (72)* | 30 – 90 (180)* | 44 – 132 (264)* | 88 – 176 |
| Number of Discs per Control Head | [-] | 2 - 6 | 2 - 6 | 2 – 6 | 2 – 4 |
| Number of Control Heads per Filter | [-] | 1 - 2 | 1 - 2 | 1 - 2 | 1 |
| Number of Segments per Disc | [-] | 20 | 20 | 20 | 30 |
| Filtrate Pipe Design | [-] | internal | internal | external | internal |
| Trough Design | [-] | common / twin** | common / twin** | common / twin** | joint single |
| Weight of segments | [kg] | 7 | 11 | 19.9 | 20 |

Table 1: Filter sizes of Boozer disc filters

(* maximum filter area with 2 control valves, ** 2 separate troughs in case of twin design with 2 control valves)

Boozer disc filters are manufactured with five disc diameters as Boozer L-type, M-type (MI with filtrate pipes inside of the barrel and ME with exchangeable filtrate pipes outside of the barrel), S-type and XS-type.

BOKELA Drum Filter

Rotary drum filters are used in numerous coal preparation plants worldwide for the filtration of fine coal slurries because of their safe and reliable operation. BOKELA drum filters impress with characteristics that are typical for the BOKELA rotary filter technology: superior process and mechanical design, excellent hydraulic characteristics and high availability.

Compared to drum filters of conventional design BOKELA vacuum drum filters

- provide up to 75 % more throughput
- achieve lower moisture contents
- discharge the cake to 100 % by compressed air repulsion even at high filter speed
- can run with high filter speed of up to 3 rpm
- have a fully automatic and reliable operation
- simplify servicing by easy maintenance

The most important innovations and improvements are

- optimised hydraulic design of filter cells and filtrate pipes leading to low pressure loss and fast filtrate removal out of the cells
 - high performance control head with pre-separation of air and liquid providing for low pressure losses at high capacities
 - back suck on the filter cloth to prevent damage on the scrapers during cake discharge

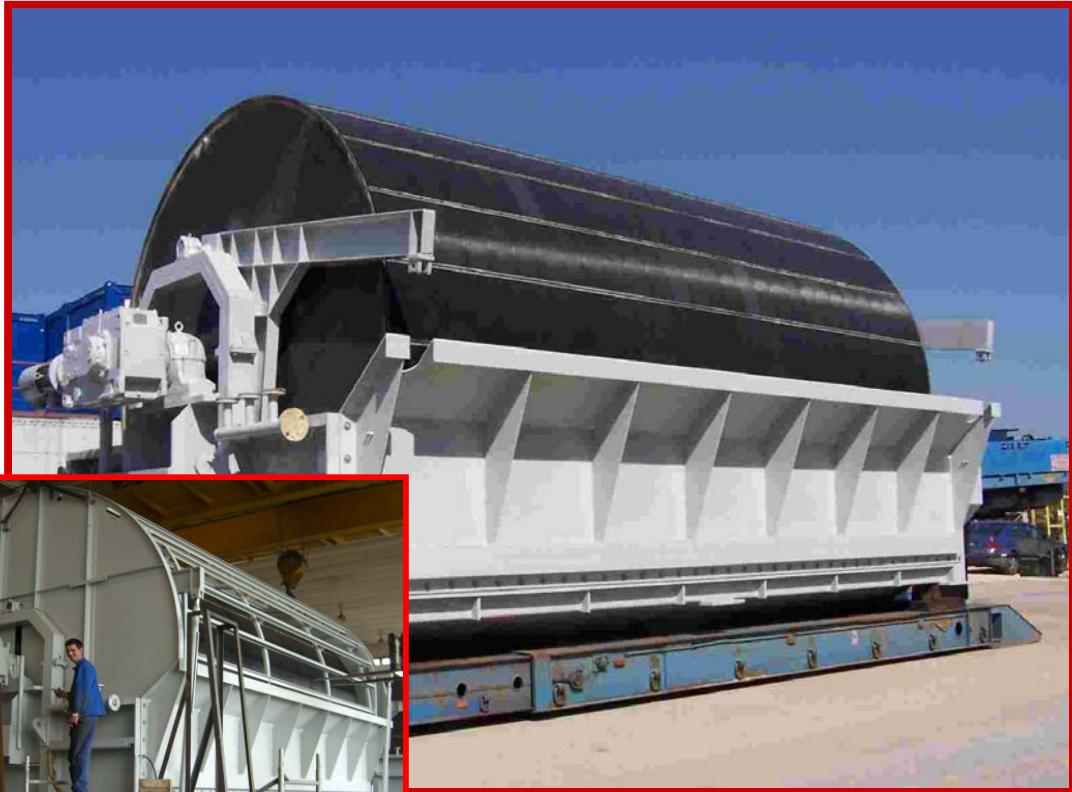

... ready for transport to its destination (86 m² filter area, 4.2 m drum diameter)

One of two BOKELA drum filters XXL -Type in the workshop ...

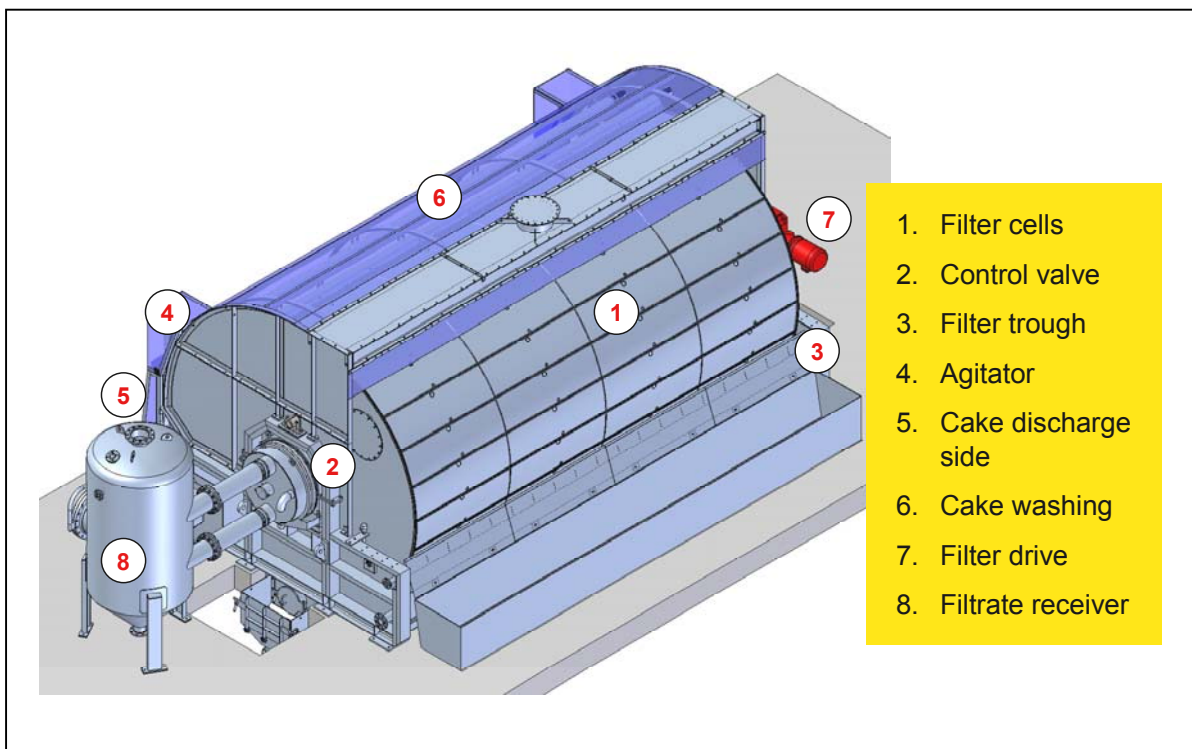

Main drum filter components

- liftable agitator that can be totally turned off without dismantling the drum
- new designed grids with low flow resistance
- exchangeable single filter cells for fast and comfortable change of filter cloth (only for smaller filter sizes)
- filter cells with exchangeable perforated plates (for corrosive products)
- booster zone i.e. connectible extra-cake forming zone (optional)

BOKELA vacuum drum filters are individually adapted to the requirements of the special filtration task and are available with different methods of cake discharge like roller discharge, scraper/air blow off or precoat discharge.

BOKELA Drum Filter Sizes

The filter sizes range from 0.5 m² up to 125 m² filter area. As a special feature our vacuum drum filter can be equipped with a steam cabin that allows a still more intensive washing and dewatering of the cake by steaming which reduces the cake moisture by some 1 – 3 %-points depending on the product.

| Filter Type | [-] | XS | S | M | L | XL | XXL |
|-----------------|-------------------|-----------|-----------|--------|---------|---------|----------|
| Drum Diameter | [m] | 0.9 | 1.4 | 1.8 | 2.4 | 3.2 | 4.2 |
| Filtration Area | [m ²] | 0.5 – 3.2 | 2.5 – 8.0 | 6 - 20 | 16 - 40 | 40 - 81 | 76 - 125 |
| Number of Cells | [-] | 16 | 20 | 20 | 24 | 24 | 24 |

Table 2: Filter sizes of BOKELA Drum Filters

Hi-Bar Filtration – Dry Filter Cakes and High Throughput Capacities

Hi-Bar Filtration of BOKELA is the most advanced continuous pressure filtration process that achieves the highest throughput rates and the lowest cake moisture contents in the filtration of fine coal slurries.

Hi-Bar Filtration is a high performance filtration process for fine bulk materials characterised by

- continuous filtration with high pressure differences up to $\Delta p = 6$ bar
- highest throughput rates
- lowest moisture contents
- large filtration areas i.e. compact plant design

Hi-Bar Filtration is performed as pressure filtration or as steam pressure filtration.

Hi-Bar Plant Design

Hi-Bar Filtration uses BOKELA rotary disc or drum filters, which are installed inside a pressure vessel that is filled with compressed air. The filtrate pipes of the rotary filter are connected to the atmosphere via the control head and the suspension is pumped into the filter trough inside the pressurized vessel. The filter cake is discharged from the cloth by an air-blow-back and removed out of the vessel by a sluice. The pressurized air which enters the vessel for the cake discharge is available for the filtration process.

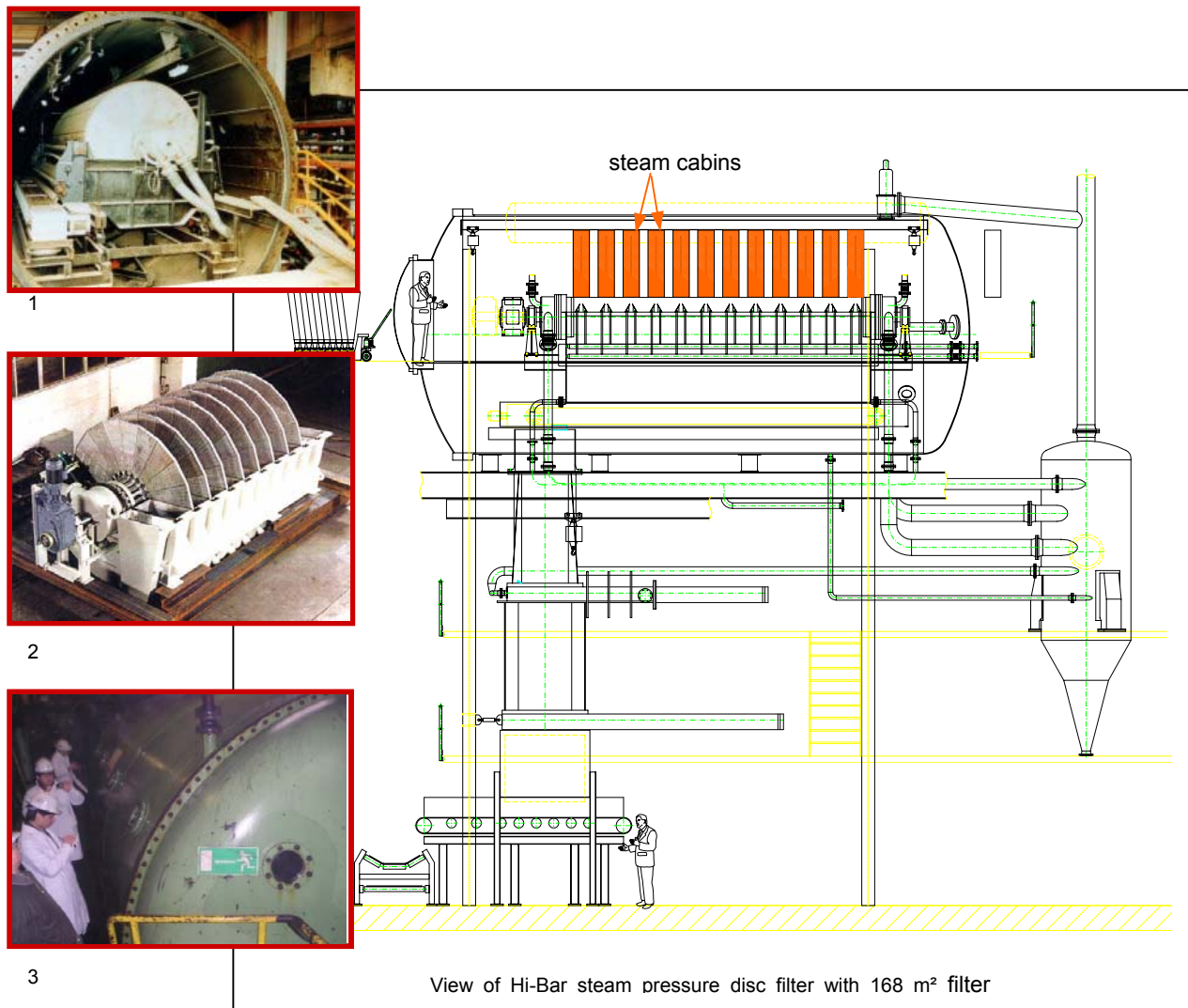

Figure 1 to 3: Hi-Bar drum and disc (fig. 1: drum filter inside the pressure vessel, fig. 2: view of a disc filter, fig. 3: view of a Hi-Bar disc filter plant in a coal washery)

Extremely Low Moisture Content with Hi-Bar Steam Pressure Filtration

The patented Hi-Bar steam pressure filtration is a combined thermal/mechanical process. This innovative separation process achieves clean and extremely dry filter cakes by activating of synergy effects that occur when a wet filter cake is treated with steam in a special way. For this a specially designed and patented steam cabin covers a part of the filter area and forms a small separated room with pure steam while the pressure vessel is filled with compressed air. The benefits are

- high specific throughput rates e.g. with fine coals of up 2 t/m²h
- extremely low moisture contents e.g. with fine coals of mc < 10 %
- low steam consumption and reduced air consumption
- marketable coals without thermal drying i.e. significant cost savings
- filtration of extremely fine materials (e.g. 90 % < 10µm)
- filtration of coal slurry with difficult filter behaviour (e.g. due to high ash content)

Dry Coal without Thermal Drying

| | Pressure Filtration | Steam Pressure Filtration |
|--|--------------------------|---------------------------|
| Solids throughput | 98 t/h | 98 t/h |
| Moisture content | 19.5 wt% | 9.8 wt% |
| Air consumption | 4,500 Nm ³ /h | 2,100 Nm ³ /h |
| Steam consumption | - | 7 t/h |
| Cost for filtration (capital, operation, energy cost) | 1.7 €/t | 2.5 €/t |
| Cost for thermal drying (capital, operation, energy cost) | 5.4 €/t | - |
| Total cost | 7.1 €/t | 2.5 €/t |

Table3: Cost comparison of fine coal dewatering with continuous pressure and Hi-Bar steam pressure filtration.

Hi-Bar steam pressure filtration of fine coals achieves extremely low moisture contents and enables to attain target moisture values for marketable coals without thermal drying. The elimination of thermal drying leads to significant cost savings due to reduced capital, operation and energy cost.

The figures in table 3 refer to the dewatering of a fine coal with $x_{50} < 60 \mu\text{m}$ and an ash content of 7.5 – 10 wt%. For this fine coal the Hi-Bar steam pressure filtration can achieve a marketable product with only 2.5 €/t instead of 7.5 €/t what are the cost for the combination of continuous pressure dewatering and thermal drying – this means 65 % cost saving with Hi-Bar steam pressure filtration.

Hi-Bar Filtration Disc and Drum Filter Sizes

| Hi Bar-Filtration Disc Filter Sizes | | | |
|-------------------------------------|-------------------|--------|----------|
| Filter Type | [-] | XS | S |
| Disc Diameter | [m] | 2.2 | 3.2 |
| Filtration Area | [m ²] | 6 - 84 | 56 - 168 |

| Hi Bar-Filtration Drum Filter Sizes | | | | |
|-------------------------------------|-------------------|----------|---------|---------|
| Filter Type | [-] | M | L | XL |
| Drum Diameter | [m] | 1.8 | 2.4 | 3.2 |
| Filtration Area | [m ²] | 6.8 - 20 | 16 - 40 | 40 - 81 |

Table 4: Hi-Bar Filtration disc and drum filter sizes

Filter Revamping – New Filtration Capacities by Retrofitting

Filter revamping is modern method developed by BOKELA to optimise running filters of old design to the latest technology and latest demands from maintenance and operating personnel. BOKELA have improved the performance and operation of disc filters in coal processing plants with great success.

Filter revamping eliminates bottlenecks in production plants and makes running filtration plants suitable for new production targets. The benefits of a filter revamping by BOKELA are convincing:

- up to 150 % performance increase
- significant cost savings since only 5 % – 30 % of new filter investment costs are necessary
- short-termed and fast realisation covered by maintenance budget and no new investment.

3 Steps to Improve Filtration

Modernisation and upgrading of filter plants with our revamping program is split in three steps: diagnostic step, engineering step and realization step. This method allows a maximum of cost control and a minimum risk.

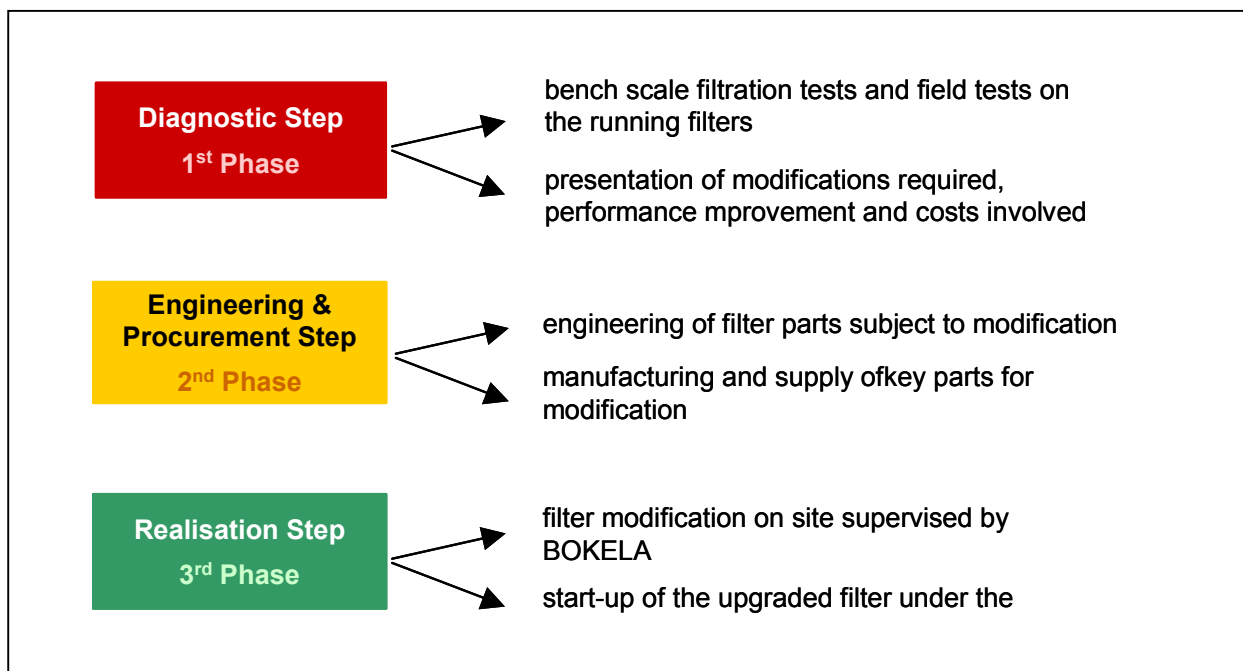

Filter revamping in 3 steps

Optimisation with Individual Modifications is a Viable Alternative to Increase Filter Capacity

Typically a disc filter revamping can be performed with a small or large package of modifications depending on the individual situation and target of the client. Thus the revamping costs range from 25 % to 75 % of the price for a new filter. The total costs of a new filter investment, however, require 3 to 4 times the price of the new filter itself due to the additional costs for building, piping, electrics, auxiliaries etc and engineering. Therefore, Filter optimisation with sensible modifications is a viable alternative to increase filter capacity and/or improve cake moistures and can replace the requirement to purchase new filters plus the infrastructure for the new filter.

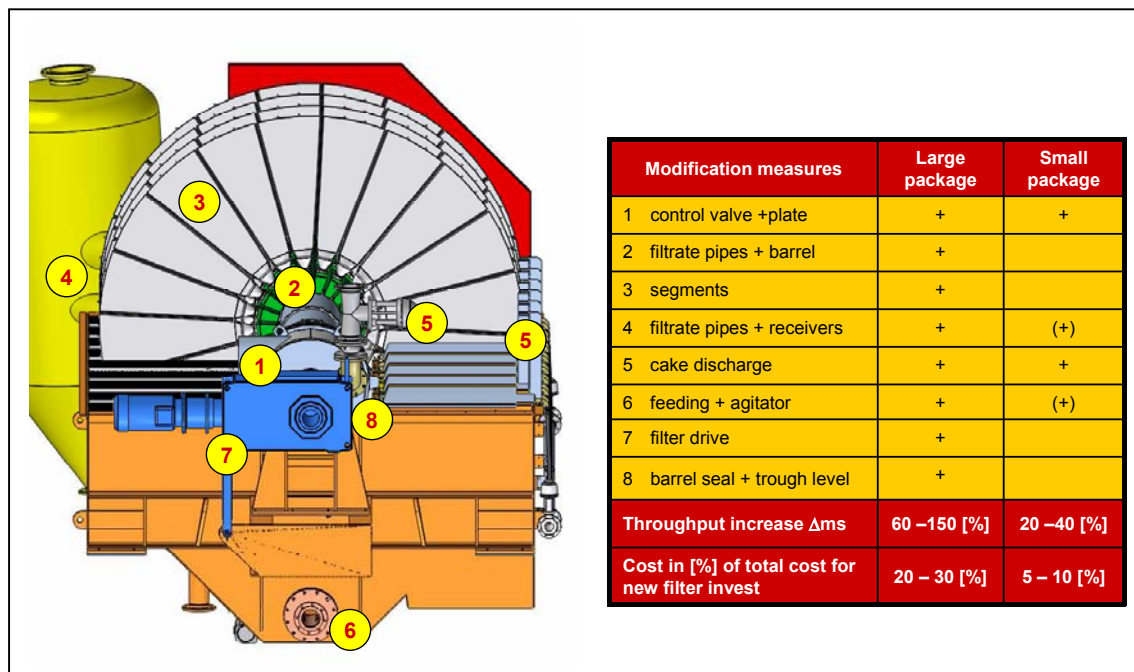

Typical modification measures, throughput increase and cost of a BOKELA filter revamping (example: disc filter) according to a large or small package of modifications

| | Before Revamping | After Revamping | |
|--|---------------------------|---------------------------|---------------------------|
| | | Predicted | In operation |
| Large package of modifications on coal disc filters at BMA Saraji | | | |
| Specific solids throughput | 270 [kg/m ² h] | 270 [kg/m ² h] | 270 [kg/m ² h] |
| Moisture content | 22,4 wt-% | 22 wt-% | 22 wt-% |
| Performance increase | Target: 100% | 100% | 100% |
| Small package of modifications on coal disc filters at BMA Norwich Park | | | |
| Specific solids throughput | 305 ka/m ² h] | 480 [ka/m ² h] | 578 [ka/m ² h] |
| Moisture content | 22,4 wt-% | 22 wt-% | 22 wt-% |
| Performance increase | | 55 % | 80 % |

Table 5: Results of disc filter revamping in coal washeries

Modern Coal Disc Filters by Revamping

BOKELA have improved running coal filters of old design to the latest BOKELA rotary filter technology. The modified filters run with better performance and improved operation behaviour and have a better maintainability (table 5). The benefits are

- Increased throughput capacity of up to 100 %
- Improved filter operation e.g. elimination of permanent slurry overflow by level control operation
- Improved maintainability e.g. reduced, safer and easier maintenance by permanent walkways, new segment fixing system, elimination of agitator etc.
- Improved production flexibility by increased spare filter capacity

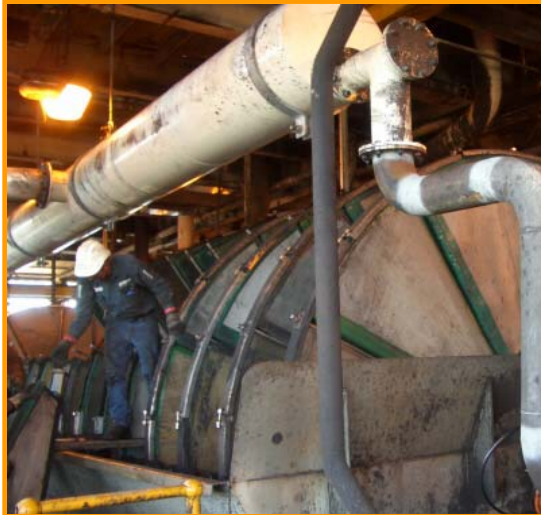

Coal disc filter before ...
(access for segment changes via plank)



... and after revamping
(improved access by permanent walkways)

1 in Filter Revamping

BOKELA is # 1 in filter revamping world-wide.

More than 250 filter optimisation / revamping projects in numerous industries and for all major filter types and OEMs such as disc filters, drum filters, pan filters, belt filters, filter presses, Kelly filters, Niagara filters etc. made BOKELA to the No. 1 expert in filter optimisation.

From Lab Test to Plant Size

The feasibility and the benefits of BOKELA filtration technologies can be tested with special designed test equipment. Lab tests and/or field tests at the site with our transportable FILTRATEST provide all relevant data and parameters which are necessary for a reliable filter up-scaling. Our mobile pilot plant with disc and drum filters of technical size allows a continuous operation at the site under real conditions.



Transportable FILTRATEST



Test operation with the mobile pilot plant at the site
in Brazil

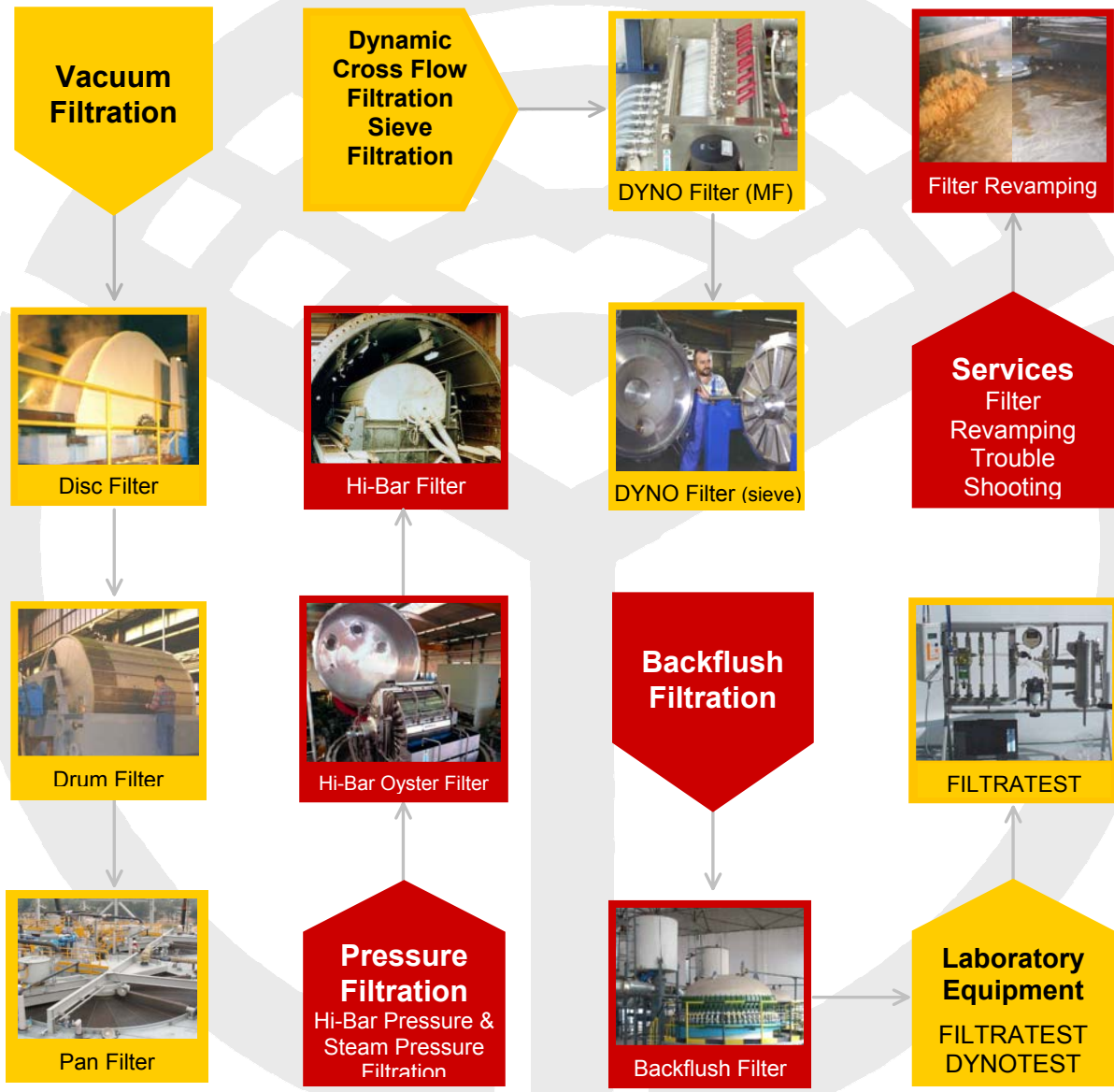

<http://www.bokela.com/>

BOKELA GmbH
Tullastr. 64
76131 Karlsruhe
Germany

phone: +49 721 96456-0
fax: +49 721 96456-10
bokela@bokela.com

BOKELA Australia Pty
Suite 15, Building 5 Spring Lake Commercial
1 Springfield Lakes Blvd.
Springfield Lakes QLD 4300
Australia

phone : +61 7 3288 1400
fax: +61 7 3288 1424
bokelaofaustralia@bokela.com

BOKELA do Brasil Ltda
R. Santiago Ballesteros 610
Sala 6, Cinco
32010-050 Contagem – MG
Brazil

phone: +55 31 2565 0976
fax: +55 31 2565 3976
bokeladobrasil@bokela.com